

# The Radial Time Projection Chamber Gas System

George Jacobs  
JLAB Physics DSG  
08/14/2018

The Radial Time Projection Chamber, RTPC, gas system performs the following functions;

- Gas supply to the Drift Monitor System, DMS, and RTPC GEM, Gas Electron Multiplier
- Monitors the absolute pressure inside the RTPC
- Monitors the differential pressure between the DMS and RTPC
- He4 purge supply for the Buffer volume (Legacy Hall B He Gas System)
- Monitors the absolute pressure in the Buffer volume between the target and RTPC

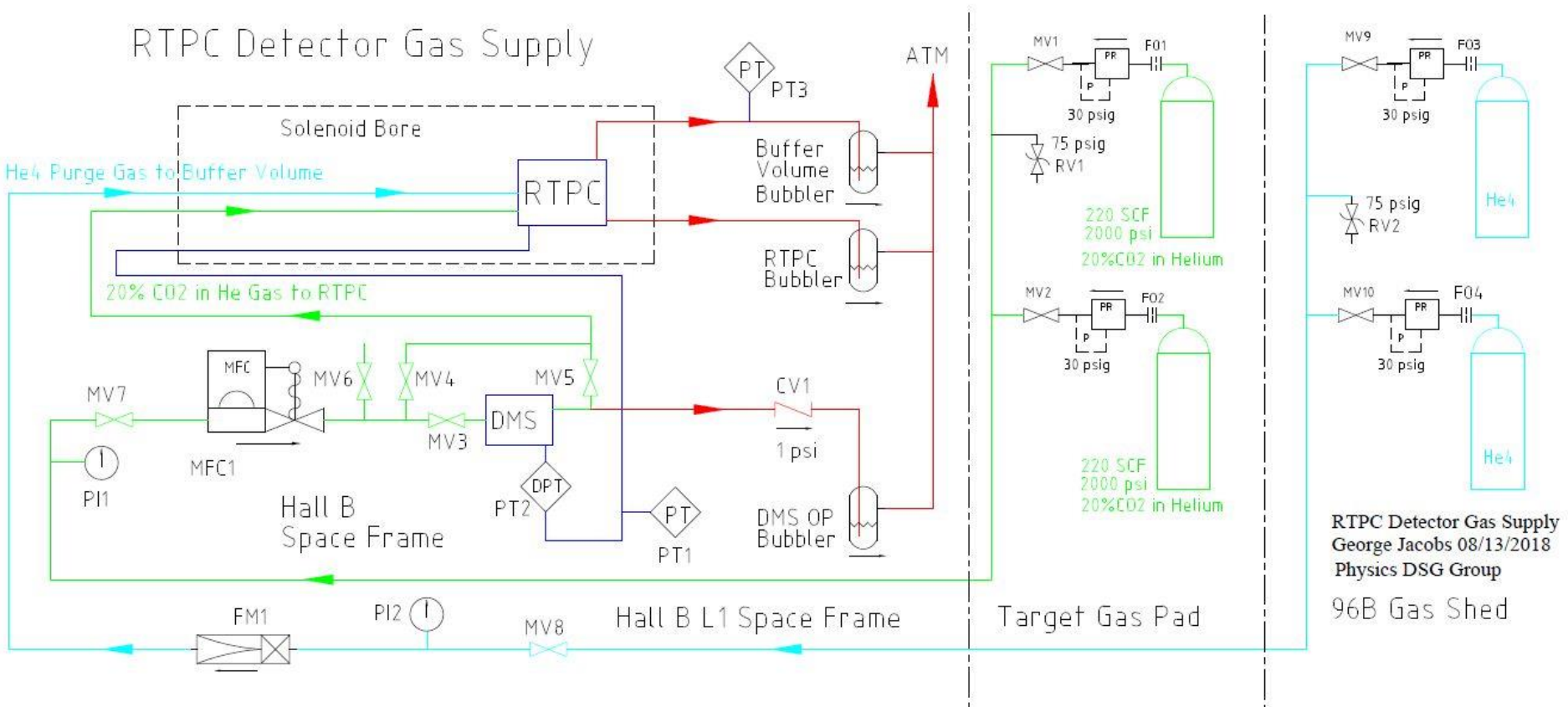

## Two gasses are used in this system.

The RTPC and DMS are supplied with 20% CO<sub>2</sub> in He pre-mix gas.

The Buffer volume between the Target and RTPC is purged with He<sub>4</sub> gas.

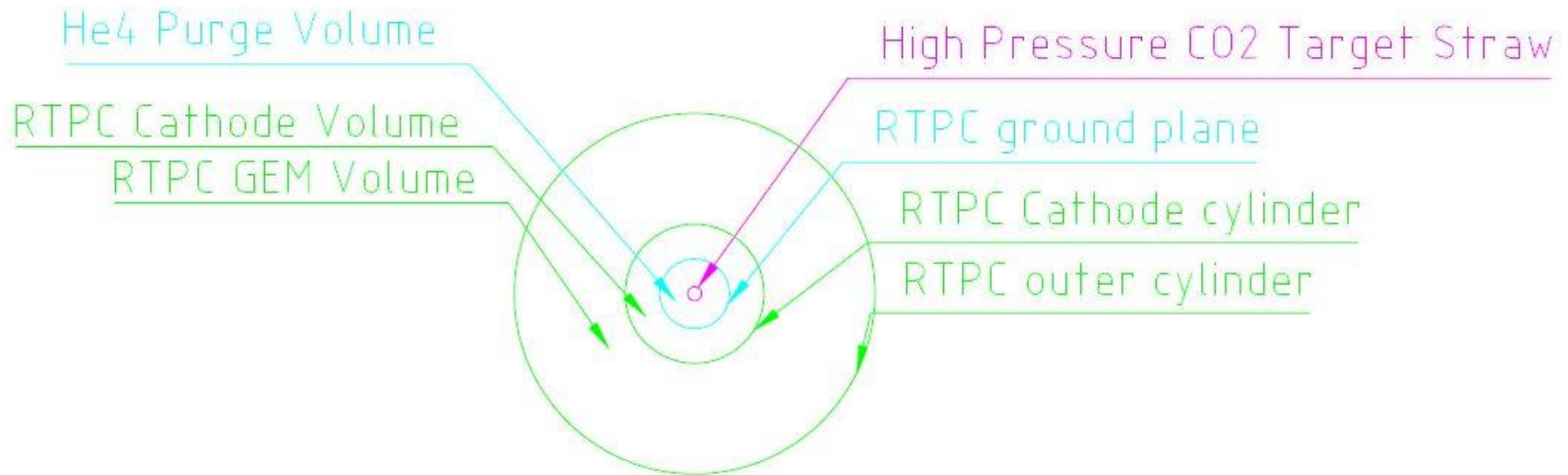

Gas flow to the RTPC and DMS gas volumes is metered by a mass flow controller.

The DMS, Drift Monitor System, measures the electron drift speed in the gas mix.

The RTPC, Radial Time Projection Chamber, tracks the particles emitted from the target.

The He<sub>4</sub> Buffer purge reduces multiple scattering between the Target and Tracker.

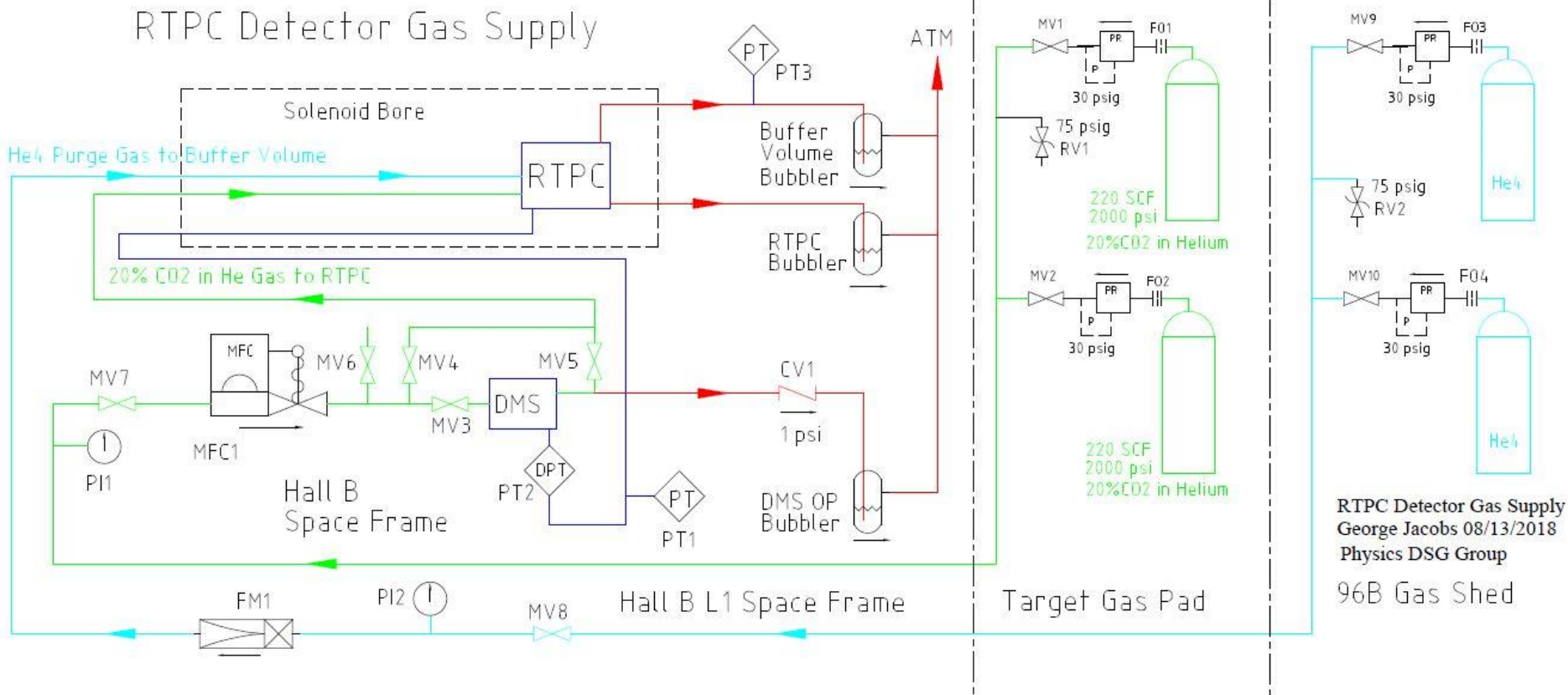

RTPC Detector Gas Supply  
 George Jacobs 08/13/2018  
 Physics DSG Group  
 96B Gas Shed

The 20% CO2 in He pre-mix gas supply is located on the Target gas pad.  
 The He4 Purge gas is located at the 96B gas shed (Legacy Hall B He Gas Supply System)  
 The gas panel is located in Hall B on Level 1 Space Frame

# RTPC Valve Panel

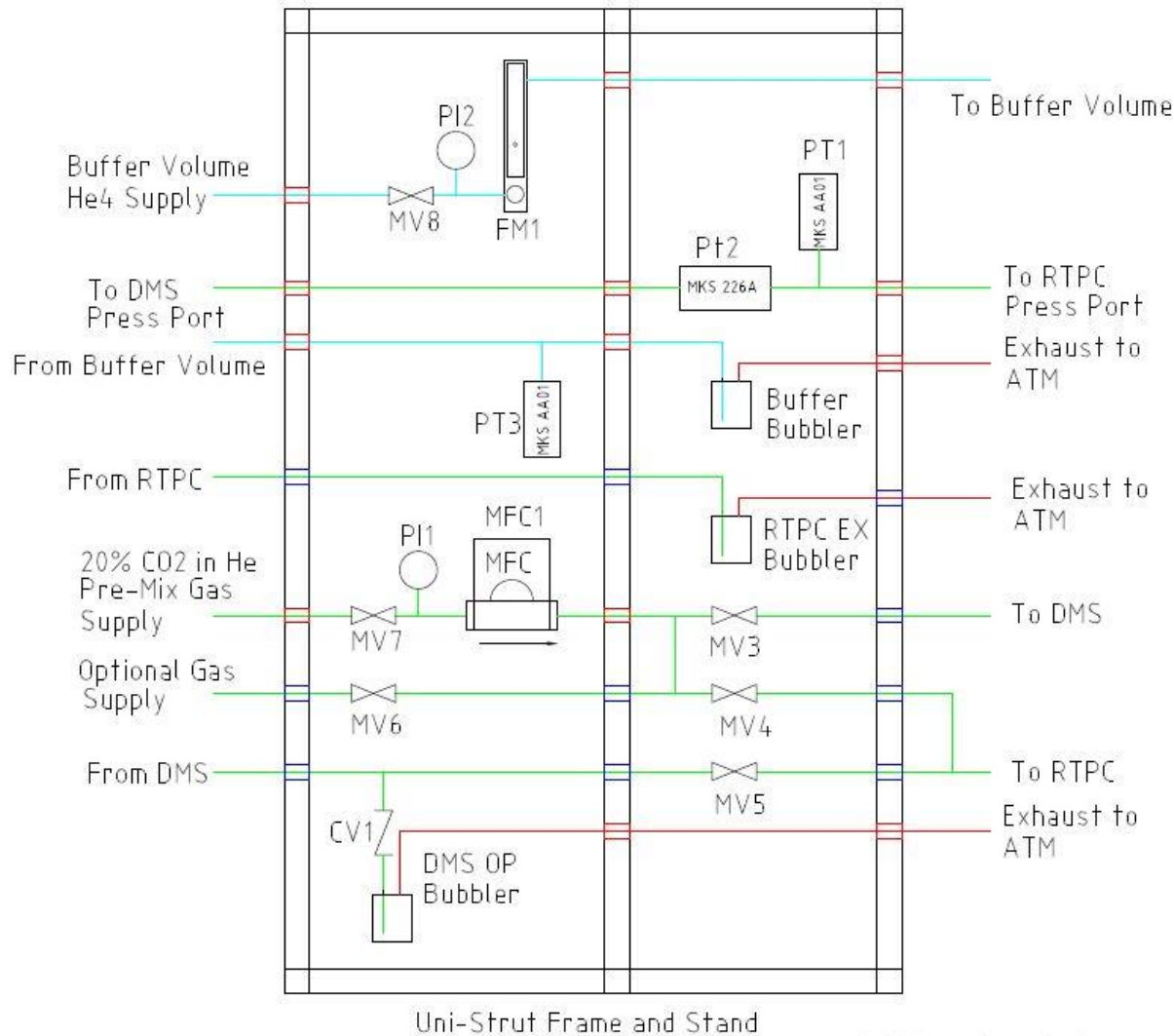

The gas system components are mounted on a compact panel to afford portability for testing prior to installation in Hall B

# Controls and Instrumentation

A GUI running on a National Instruments cRio is used to control the MFC and read back the four gas system flow and pressure signals.

These signals are available on EPICS.

- RTPC Gas Flow
- RTPC Absolute Pressure
- DMS-RTPC Differential Pressure
- Buffer Absolute Pressure

## Conclusion

RTPC Gas System design is complete.

A pressure systems design authority has been assigned.

RTPC Gas System Construction is in progress.

“Sorry to say, I’ve plain run out of things to nag about - it’s perfect!” – Sebastian K.